

IMPORTANT NOTE

Your BilgelQ has a WiFi network name "**BilgelQ-xxxx**" where **xxxx** is your unique 4 digit code. The default Password = "**PASS-xxxx**", where **xxxx** is the same unique four-digit code at the end of the WiFi network name.

To access the web interface, <http://192.168.1.1> or <http://BilgelQ.local>

BilgelQ NMEA 2000 Bilge Pump Controller

Installation and instruction Manual



1. Introduction

Congratulations on the purchase of your BilgelQ. This product is designed to monitor and control 12v or 24v bilge pumps, up to a **maximum current of 10A**. With intelligent MOSFET switching and current measurement circuitry, BilgelQ can provide an insight into the behaviour and performance of this important but often forgotten piece of equipment. The NMEA 2000 data and alerts that it produces can be displayed by any compatible MFD display.

BilgelQ will work with automatic bilge pumps (pumps with integral float switch) or bilge pumps that are designed to work with a separate float switch.

An optional 2nd Float Switch can also be fitted to provide a second level of alerting if the bilge water reaches a critical level – decided by the location of this second float switch.

 **This Product Guide provides important information that we recommend you read before attempting to install or use this BilgelQ unit. If you have any concerns or questions, please visit our Support website at <https://digitalyacht.support> and raise a support ticket.**

2. Before you start

You will need the following items and tools to complete the installation:

- The BilgelQ unit.
- A suitable NMEA 2000 drop cable (not supplied).
- Wiring diagram and specification of the bilge pump to be used.
- Optional 2nd float switch.
- M4 screws (not supplied) or other fixings appropriate to the mounting location.

To configure the unit, you will need:

- A wireless mobile device such as a smart phone or tablet, which has a modern web browser like; Safari, Google Chrome, Firefox, Microsoft Edge, etc.

3. Installation

Before starting installation select a suitable location for the BilgelQ unit. The unit is waterproof, but we recommend that it is permanent mounting below deck in a dry location. It should be noted that the M20 Gland which the Bilge Pump cable will be fitted through, is designed to seal against the insulation of a round cable. Often Bilge Pump cables are individual wires which compromises the integrity of the M20 gland and additional sealing methods may need to be employed to achieve IP68 levels of waterproofing.

When locating the unit, you should consider:

- Routing of the 7-core Power/Signal cable to a suitable power source
- Routing of an NMEA 2000 cable to a spare “T-Piece” on the NMEA 2000 network
- Space around the BilgelQ enclosure to allow cables to be comfortably routed
- If you need Wi-Fi reception around the whole boat
- Maintaining the compass safe distance of 0.5m
- Connection to other devices/accessories



Installation Step 1 – Mechanical Mounting of the Unit

The BilgeIQ can be mounted in any orientation, but we recommend mounting it on a vertical surface with the NMEA 2000 connector pointing down. The BilgeIQ enclosure has two mounting lugs which features 5mm fixing holes. We recommend a No.10 wood screw or M5 bolt to secure the unit in place, but please do not apply undue force when tightening which could damage the plastic.

Unit Dimensions

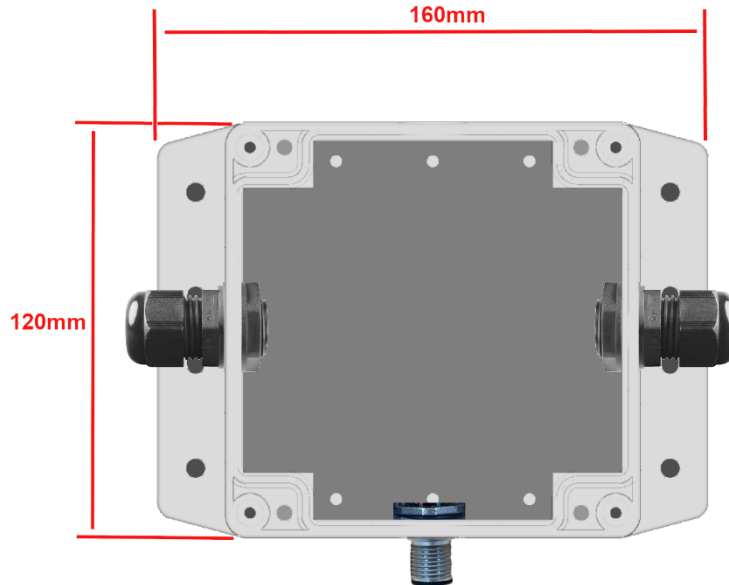

Installation Step 2 – Wiring

The following diagram shows BilgeIQ connected to a typical “Auto” bilge pump that has its own internal float switch. The diagram also shows the three-position switch panel wiring, which is commonly found on many boats.

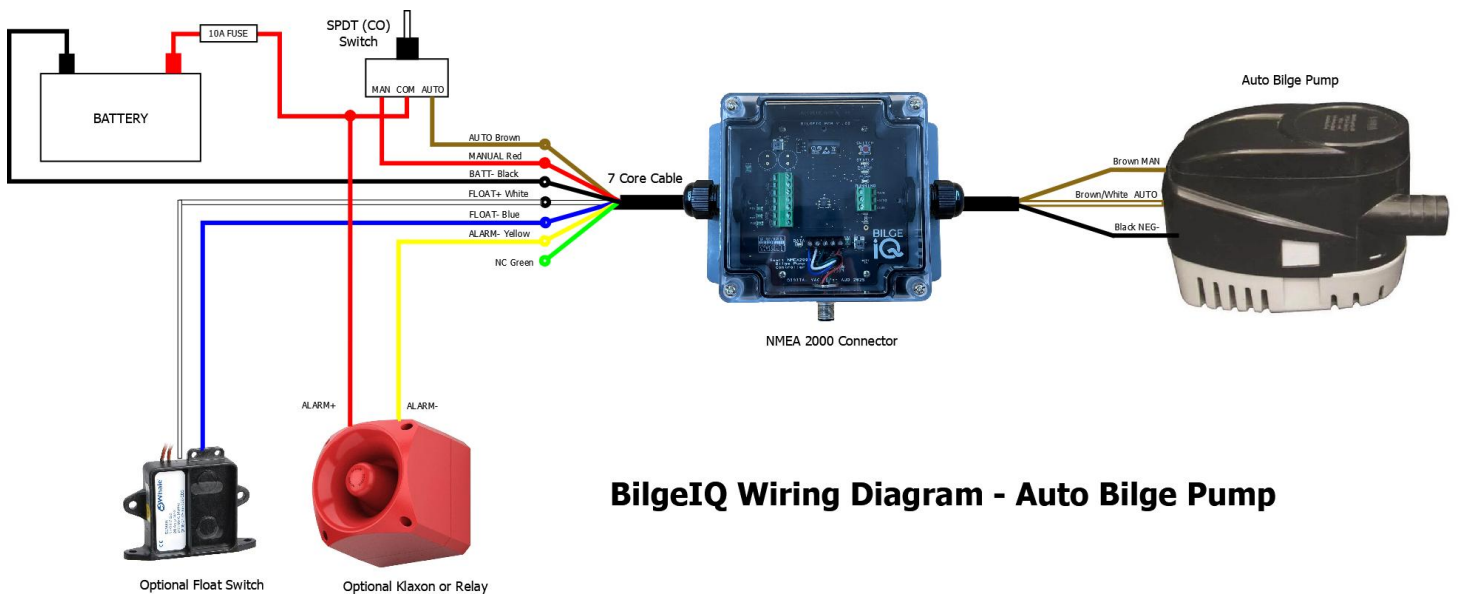

BilgeIQ Wiring Diagram - Auto Bilge Pump

The function of each wire in the 7-core cable is detailed in the table on the next page. The three-way terminal block is designed to connect to a standard 3 wire automatic bilge pump. There is no official standard for bilge pump wiring colours, but most use the following colours.



Wire Color	Function	3 Way Terminal Block connection
Brown	Positive (+)	"MAN" terminal
Brown/White Stripe	Auto Positive (+)	"AUTO" terminal
Black	Negative (-)	"GND" terminal

Please note that the cable glands are designed to clamp down and create a waterproof seal on a single round insulated cable. If your bilge pump has three individual wires with no outer insulation, then the gland may struggle to create a waterproof seal. If a waterproof seal is required, then consider fitting a small section of adhesive backed heat shrink over the three wires (where they enter the gland) or apply a small bead of sealant to the gland after inserting the wires but before tightening the gland, so that the gaps are filled with sealant.

With BilgelQ wired as shown, the three-position bilge switch panel operates as follows...

1. OFF - BilgelQ will be powered OFF
2. AUTO - BilgelQ is powered ON and the bilge pump will activate as normal when its float switch closes
3. MAN - BilgelQ is powered ON and the bilge pump will be constantly active

Wire colour	Description	Function
RED	Manual	12/24v positive power for Manual operation
BROWN	Automatic	12/24v positive power for Automatic operation
BLACK	Power in -	0v negative power
WHITE	Float+	Positive connection for 2 nd Float Switch
BLUE	Float-	Negative connection for 2 nd Float Switch
YELLOW	Alarm-	Switched negative (open collector) output to Klaxon
GREEN	Not Used	Reserved for future use (no connection)

Installation Step 3 – Connecting to NMEA 2000 Network

To connect the BilgelQ to an NMEA 2000 network, it will be necessary to fit an NMEA 2000 drop cable with maximum length of 6m (not supplied). BilgelQ has a standard micro M12 NMEA 2000 male connector on its base.

BilgelQ is not powered from the NMEA 2000 network and has a LEN of 1.

If you need to create a new NMEA2000 network, then you may wish to consider [Digital Yacht's NMEA2000 Starter Kit](#), that provides all of the cables, connectors and terminators required for a basic NMEA2000 network.

A table showing all the NMEA2000 PGNs (messages) that BilgelQ transmits and receives are shown below. Please note that the mandatory NMEA 2000 bus management PGNs are not listed.

Transmit PGNs List	
PGN No.	PGN Title
126983	Alert
126985	Alert Text
126993	Heartbeat
127501	Binary Status Report
127506	DC Detailed Status
127508	Battery Status
127751	DC Voltage/Current



Receive PGNs List	
PGN No.	PGN Title
126208	NMEA – Command Group Function
126984	Alert Response
126992	System Time
127502	Switch Bank Control
129029	GNSS Position Data

By default, BilgeIQ outputs the voltage and current being supplied to the bilge pump in PGN 127751 DC Voltage/Current. However, if your MFD does not support this PGN, you can set BilgeIQ to output PGNs 127506 DC Detailed Status and 127508 Battery Status. This is set in the SETTINGS page of the web interface.

Installation Step 4 – Connecting 2nd Float Switch and Klaxon

Bilge IQ has an input for a 2nd float switch and an output for a DC Klaxon/Alarm.

Any 3rd party float switch can be used to trigger an alarm that the bilge water levels have reached a critical level, indicating that the pump(s) are not keeping up with the rate of water ingress. When the 2nd float switch closes BilgeIQ will alarm and transmit a second Alert PGN on the NMEA 2000 network.



If you are interested in fitting an external alarm, our [NAVAAlarm NMEA 2000 Klaxon](#) is the ideal alarm for any NMEA 2000 Alerts and simply plugs in to the NMEA 2000 network, taking its power and data from the network. However, if you already have DC buzzer/alarm then it can be wired to the BilgeIQ's Alarm output, which is an open-collector transistor with a 350mA fuse.

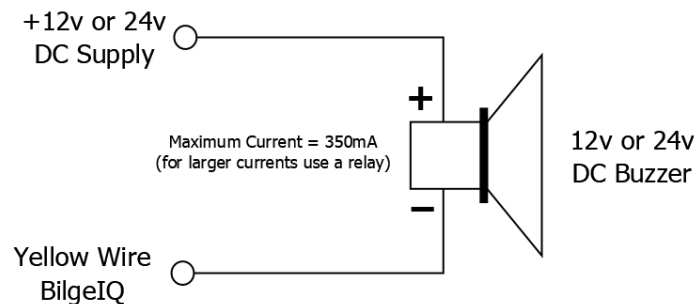



4. Operation

When powered up BilgelQ displays a series of indicator LEDs on its PCB, visible through its clear plastic enclosure lid.

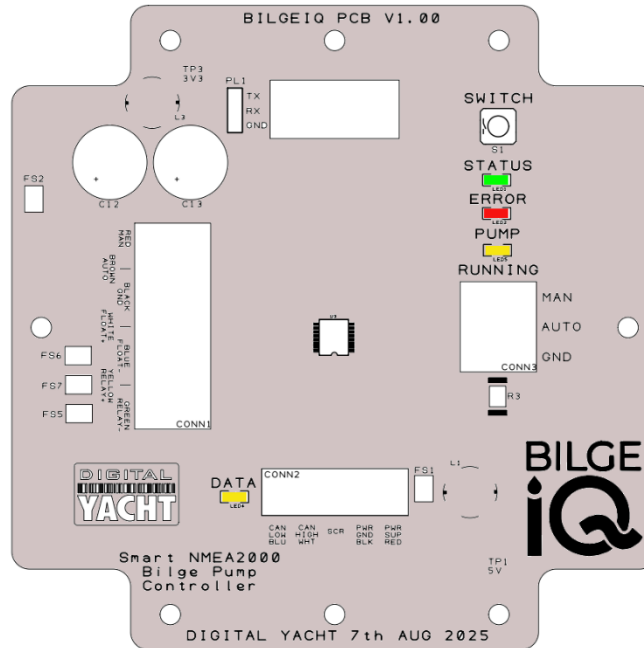

The LEDs illuminate in order; STATUS, ERROR, PUMP RUNNING and then DATA. Then the STATUS LED will flash and after a few seconds the DATA LED will flash as BilgelQ joins the NMEA 2000 network. The table below provides a key to what the LEDs mean.

Condition	STATUS LED (Green)	ERROR LED (Red)	PUMP RUNNING LED (Yellow)	DATA LED (Yellow)
ON (Solid)	Wi-Fi STA Mode Connected	Error condition has occurred check web interface	Pump Running Controller by BilgelQ	Not connected to NMEA 2000 network
Flashing	Wi-Fi AP-Mode Active	N/A	Pump Running by manual control of 3 way switch	Connected to NMEA 2000 network
OFF	N/A	All OK	Pump not Running	No Web Connection

By default, BilgelQ creates a wireless network (Access Point), with Name (SSID) = “BilgelQ-xxxx” and Password = “PASS-xxxx”, where xxxx is a four digit code, unique to your device. For example, if your BilgelQ creates a wireless network called OneFix-D4F8, then the Wi-Fi password will be PASS-D4F8.

To connect to BilgelQ, you need to scan for wireless networks, find it, select it and then enter the default password when prompted. If everything is OK, then your wireless device will show as “Connected with No Internet”.

This is perfectly normal as BilgelQ is not a router/gateway, so when connected to it, you will not have an internet connection. Some operating system; Windows, iOS, Android, etc. may ask you if you wish to say connected, make sure you say YES to this.

As soon as your wireless device is connected, you should be able to access the BilgelQ web interface by opening a web browser (Safari, Chrome, Firefox, Edge, etc.) and either enter the IP address of the BilgelQ...



<http://192.168.1.1>

...or if your device supports Bonjour/mDNS you can enter the following URL...

<http://BilgeIQ.local>

...which is useful if you have connected the BilgeIQ to another wireless network and don't know what IP address it has been given.

You should now see the BilgeIQ web interface, home page.

The home page gives you access to all of the BilgeIQ functionality; the STATUS, HISTORY and SETTINGS pages.

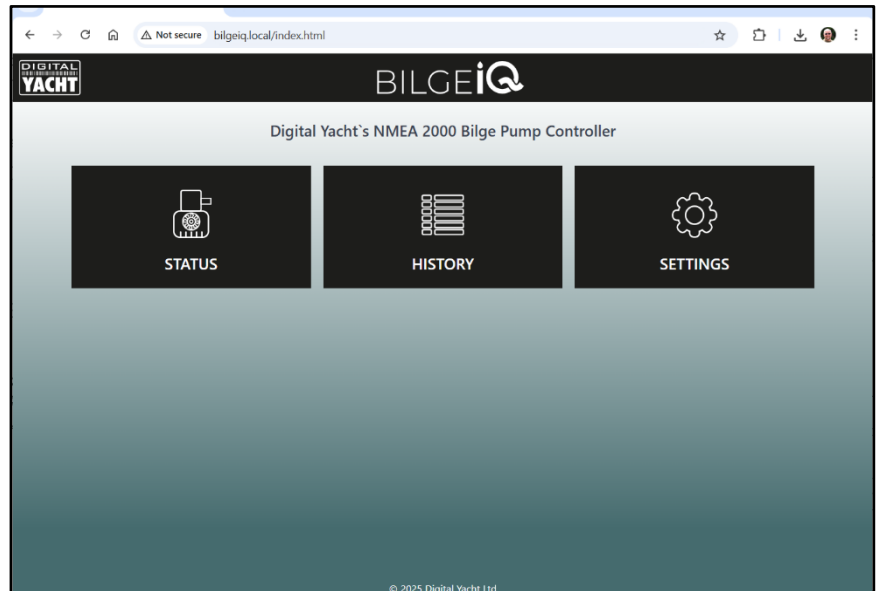

Figure 1

4.1 STATUS Page

The STATUS page as shown in Fig 2, is where you can display the BilgeIQ status and manually activate the bilge pump to test it.

For the majority of the time, the BilgeIQ "Switch" will be set to OFF (AUTO) and in this mode, your automatic bilge pump will operate as normal, activating when its internal float switch closes.

BilgeIQ will monitor the voltage to the pump and most importantly, the current to the pump which confirms the pump is actually running.

In addition BilgeIQ will monitor the runtime and number of cycles the pump makes during the day and in total, since installed.

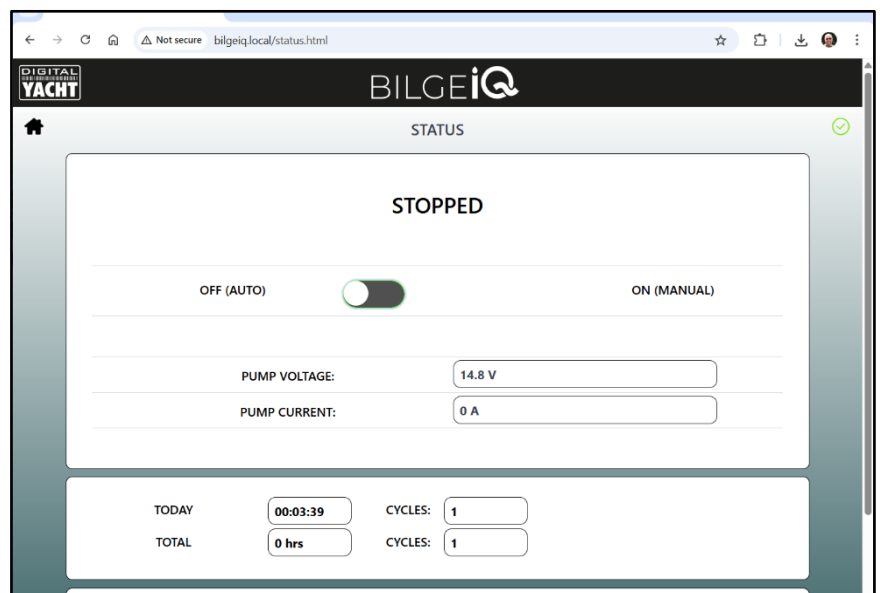

Figure 2

Also, at the bottom of the page, is a list of all Errors that have occurred. This list can be cleared by pressing the "CLEAR" button. Below are the different Errors that BilgeIQ supports...

- BILGE PUMP NOT RUNNING
- BILGE PUMP FAILURE
- BILGE WATER AT 2ND FLOAT SWITCH
- BILGE PUMP HIGH CURRENT
- BILGE PUMP LOW VOLTAGE
- REPLACE FILTER



If you wish to test the bilge pump to ensure it is operating correctly, click the Switch to ON (MAN) and the page will change to Fig 3 with the Pump Current displayed.

If there is a problem and no current is detected, an Error will be displayed.

If you have a 3 way bilge pump switch and you set this to manual ON, then the page shown in Fig 4 will be displayed.

Note it says "RUNNING" but the switch is shown as OFF (AUTO) because the pump has been turned on manually from the external 3 way switch and not the BilgelQ web interface.

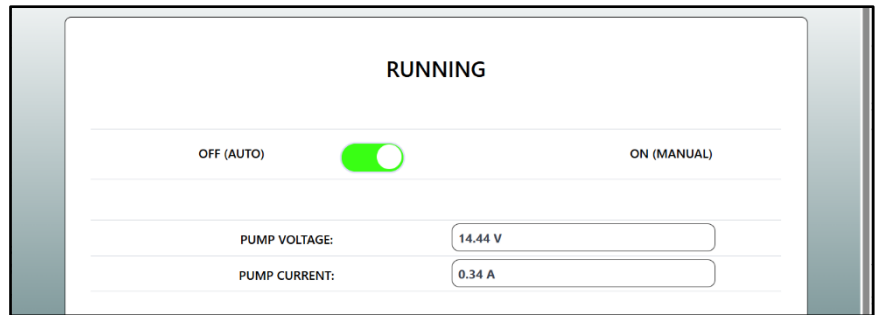

Figure 3

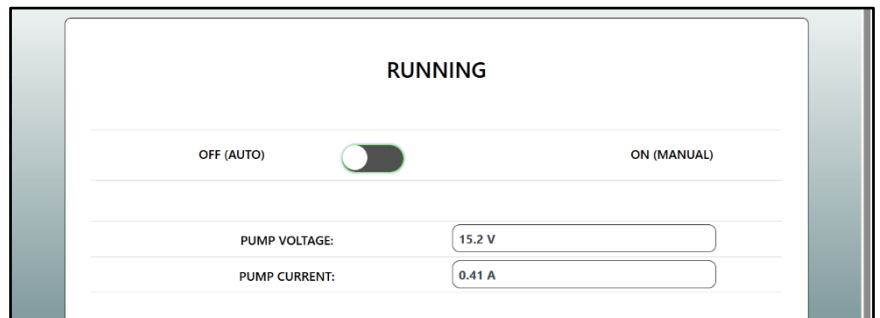

Figure 4

4.2 HISTORY Page

The BilgelQ History page as shown in Fig 5 provides a graphical display of bilge pump activity.

BilgelQ will store up to 7 days of history and display them as a bar graph.

Also down the bottom of this page is the runtime/cycles counter and the Error Log.

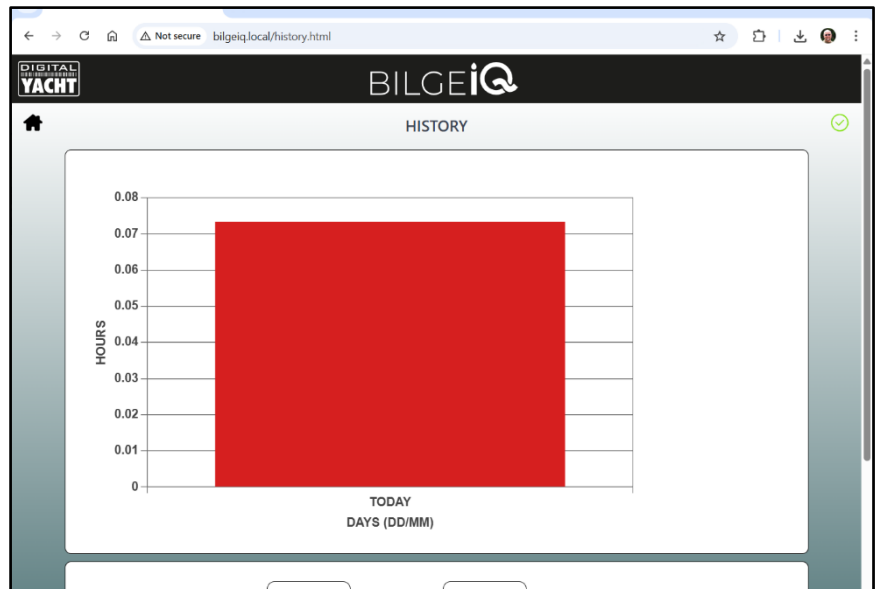

Figure 5

4.3 SETTINGS Page

By default, BilgelQ creates its own wireless access point (AP Mode). On the BilgelQ SETTINGS page, you can configure the wireless network name (SSID) and the wireless password of the network that BilgelQ creates as shown in Fig 6.

Once changed, click on the UPDATE SETTINGS button to save the new settings - NOTE BilgelQ will reboot.

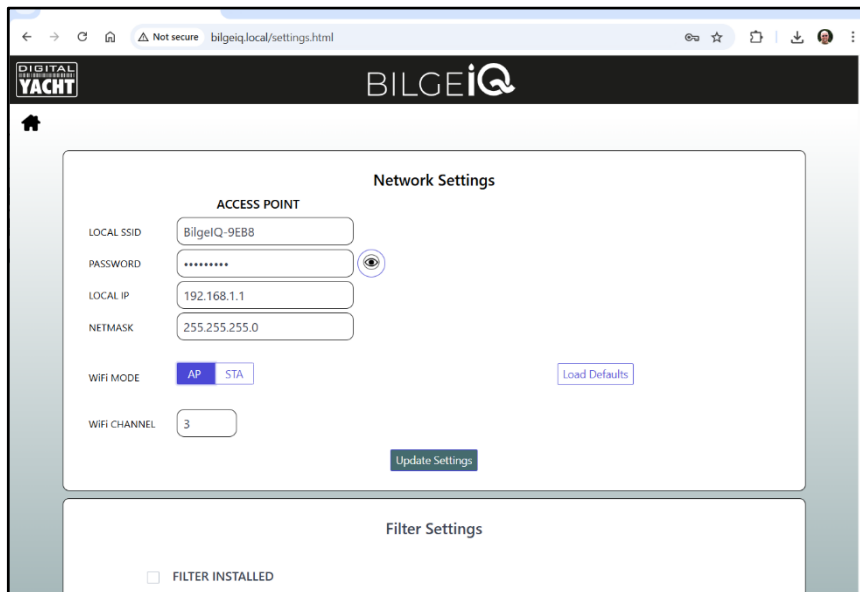

Figure 6

If you already have a wireless router on the boat, you can make BilgeIQ join that network, rather than create its own. Click on the STA (Station Mode) button, select the network you want to connect to from the drop-down STATION SSID menu and then type in the wireless password for that network – you can click on the “Eye” icon to see what password you have typed to avoid mistakes.

Click on the UPDATE SETTINGS button to save the new settings - NOTE BilgeIQ will reboot.

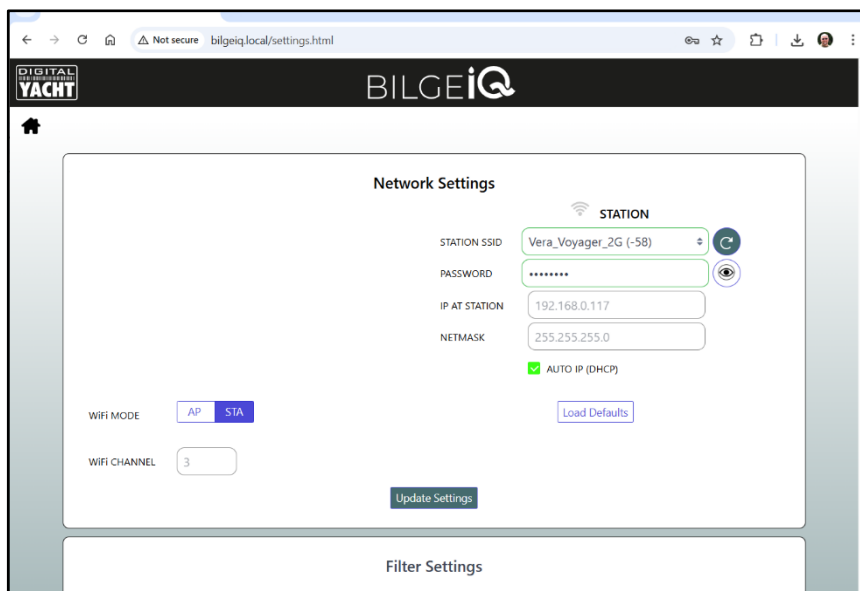

Figure 7

Also on the SETTINGS page are the Filter Settings. If you have a bilge water filter system fitted, BilgeIQ can keep track of and remind you when the filter needs replacing. If you have a filter fitted, scroll down to the Filter Settings and click the “Filter Installed” tick box. Now some extra settings will be displayed as shown in Fig 8.

Set the Hours Runtime period and the Months Since Install period and BilgeIQ will alert if either of the conditions occur.

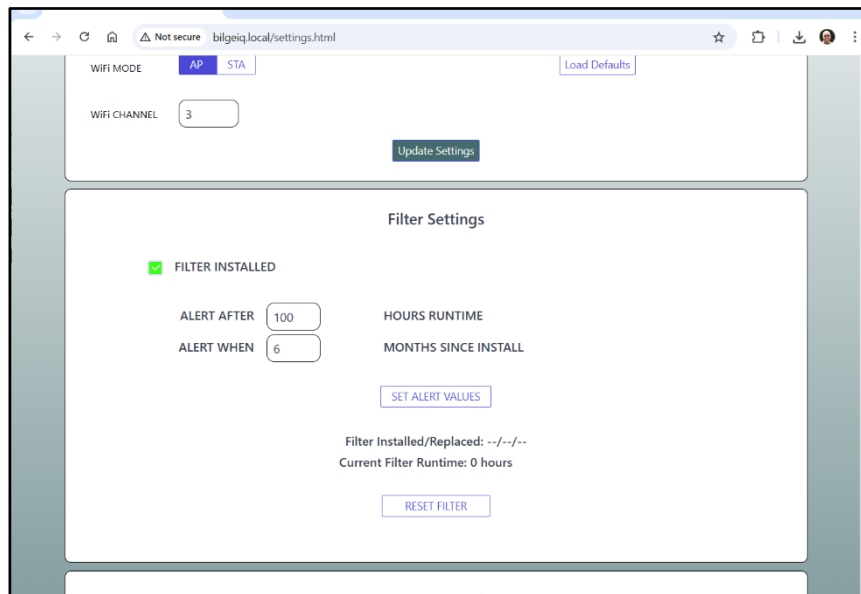

Figure 8

Scroll down the page and you will see the NMEA 2000 settings that decide how BilgeIQ behaves on the network. The first setting decides what electrical Instance BilgeIQ uses. You need to make sure that the chosen instance number is unique to BilgeIQ and no other electrical switching device is using it.

BilgeIQ uses Switch1 in the Binary Status PGN#127501.

By default, BilgeIQ outputs the voltage and current being supplied to the bilge pump in PGN 127751 DC Voltage/Current. However, if your MFD does not support this PGN, you can set BilgeIQ to output PGNs 127506 DC Detailed Status and 127508 Battery Status.

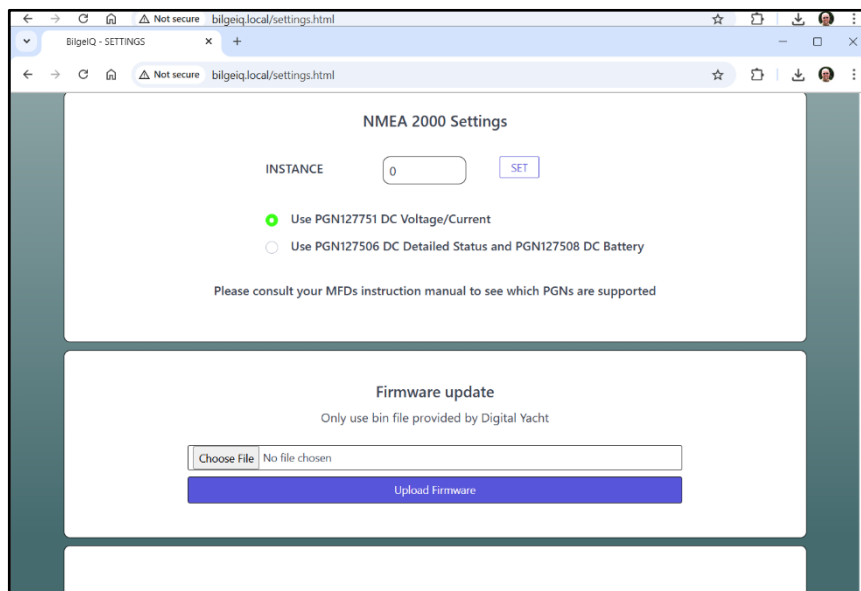

Figure 9

Finally on the SETTINGS page is the firmware update section. Updates to the firmware can be easily done via the web interface. Please monitor our <https://digitalyacht.support> site for new firmware and all the latest product news on our social media channels.