



SAIL BOAT



SPORT FISHING



MOTOR BOAT

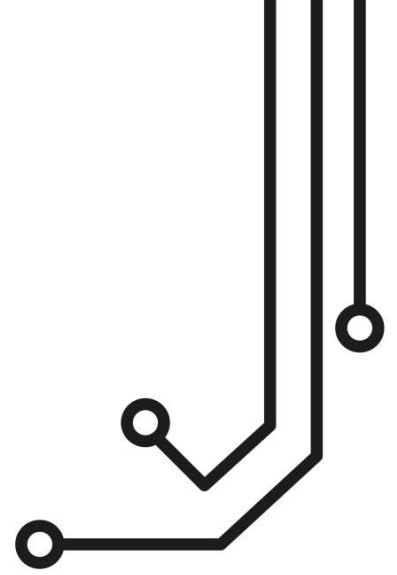

GPS160F (Furuno Compatible) **POSITIONING SENSOR**

Installation and instruction Manual



1. Introduction

Congratulations on the purchase of your GPS160F Global Navigation Satellite System (GNSS) Positioning Sensor. It is recommended that this product is installed by a Furuno Dealer or Professional Installer with Furuno experience. You will need to purchase a suitable 1" x 14 TPI thread mounting bracket for the GPS160F.

The GPS160F utilises the latest in GNSS technology, but is designed to be compatible with the thousands of legacy Furuno systems still providing reliable service, on boats around the world. Featuring a dedicated "Furuno" mode that outputs the older NMEA 0183 V2.30 data at 4800 baud, with the sentences, number of decimal places and satellite status information, that legacy Furuno systems need.

Furuno's product range is popular, reliable and extensive, which means that there are a large number and wide variety of older Furuno systems being used around the world. This manual tries to cover the most common Furuno installations, showing how the GPS160F can be used as a drop in replacement for any GP310/GP320 or GP32 systems that have failed. If your Furuno product is not mentioned in this manual, please consult your local Furuno Dealer for advice.

 Before operating the unit you should also familiarise yourself again with the user manual of the Furuno equipment that you are connecting the GPS160F to. Pay particular attention to the GPS Interfacing section and any settings that need to be configured for correct operation.

2. Installation

Before starting installation select a suitable location for the GPS160F Receiver. The unit is water proof and designed for on-deck mounting. The GPS160F antenna has the popular 1" x 14 TPI thread mount, found in many VHF antennas. A wide variety of different brackets are available for this type of threaded mount, consult your local marine electronics dealer or chandlery for more information.

The 1" x 14 TPI thread mount can also be removed by unscrewing the three hex bolts with a suitable Allen Key, allowing the GPS160F to be flush mounted on a flat horizontal surface. A mounting kit (as shown in the diagram below) is available from Digital Yacht (Part# X500.400). In this situation, a bead of silicone sealant should be applied around the antenna, after mounting it, to avoid standing water accumulating under the antenna.

Dimensions;

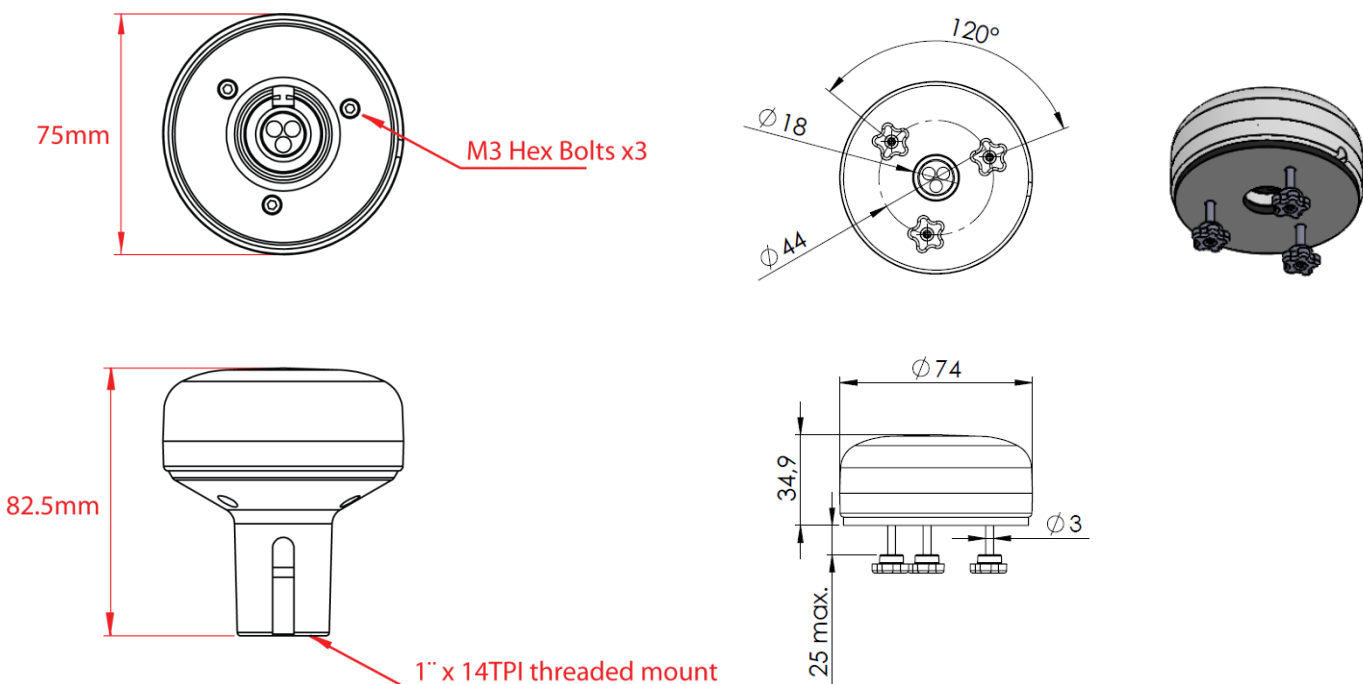



GPS160F Power/Data Cable – wire colours;

The GPS160F is supplied with 10m of cable and this should be routed through the vessel to a suitable dry internal location where it can be connected to the Furuno equipment it will be interfaced with. The cable can be shortened, lengthened or joined without problems.

If the GPS160F is to be powered directly from the boat's DC supply, then a 1 Amp fuse should be fitted in the positive power feed. The unit requires 9.6V to 30V supply voltage and consumes 30mA at 12v.

Colour	Primary
Red	Power + (12v or 24v)
Black	Power – (0v)
Yellow	NMEA Out +
Green	NMEA Out –
White	NMEA IN+
Blue	NMEA IN-

Furuno Power/Data Cables – wire colours;

Pin Number	Use	Colour
1	TD-TX Data Hot / A (+)	White
2	TD-TX Data Cold / B (-)	Black
3	RD-RX Data Hot / A (+)	Yellow
4	RD-RX Data Cold / B (-)	Green
5	12 V DC Output (+)	Red
6	GND (-)	Blue
7	Shield/Screen (FG)	Silver/bare

7 pin Data Cable

Description: MJ-A7SPF0003-050C (Black in colour)

Pin Number	Use	Colour
1	TD-TX Data Hot / A (+)	White
2	TD-TX Data Cold / B (-)	Blue
3	RD-RX Data Hot / A (+)	Yellow
4	RD-RX Data Cold / B (-)	Green
5	12 V DC (+)	Red
6	GND (-)	Black
7	Shield/Screen (FG)	Silver/bare

7 pin Power/Data Cable (GP-32, NX-300 etc....)

Description: MJ-A7SPF0009-020C (White/Cream in colour)

Description: MJ-A7SPF0007-050C (Black in colour)

Pin Number	Use	Colour
1	TD-TX Data Hot / A (+)	White
2	TD-TX Data Cold / B (-)	Black
3	RD-RX Data Hot / A (+)	Yellow
4	RD-RX Data Cold / B (-)	Green
5	Not connected (NC)	
6	Shield/Screen (FG)	Silver/bare

6 pin Data Cable

Description: MJ-A6SPF0003-050C (Black in colour)

Pin Number	Use	Colour
1	TD-TX Data Hot / A (+)	Yellow
2	TD-TX Data Cold / B (-)	Green
3	RD-RX Data Hot / A (+)	White
4	RD-RX Data Cold / B (-)	Blue
5	12 V DC (+)	Red
6	GND (-)	Black
7	Shield/Screen (FG)	Silver/bare

7 pin Power/Data Cable (GP-320)

Description: MJ-A7SPF/SRMD-100 (White in colour)

Pin Number	Use	Colour
1	TD-TX Data Hot / A (+)	White
2	TD-TX Data Cold / B (-)	Blue
3	RD-RX Data Hot / A (+)	Yellow
4	RD-RX Data Cold / B (-)	Green
5	Temp In	Brown
6	Temp In 0v	Orange
7	12 V DC input (+)	Red
8	GND (-)	Black
9	NC	
10	Shield/Screen (FG)	Silver/bare

10 pin Power/Data Cable (FCV Sounders)

Description: KON-004-02M (Black in colour)



There have been a large number of different models of Furuno equipment that can be connected to a GPS and to cover every possible combination in this manual would be impossible. The cable assemblies listed above are the most common and you will note that the Pin Numbers for the two NMEA RX signals are consistent across all cables (Pins 3 and 4) and only the colours are sometimes different.

If in doubt as to which Furuno cable you are connecting the GPS160 to, we suggest that you use a multi-meter set to measure resistance or continuity and with the cable disconnected from the Furuno equipment, check what wire colours are connected to Pins 3 and 4, which are always the two pins that our GPS160F needs to connect to.

When replacing a Furuno GP310 or GP320 sensor, the easiest method is to use the existing 10m cable which has a 7 Pin connector that plugs in to the Furuno equipment. Find a suitable location to join the two cables and cut the existing GP310/320 cable and remove the faulty sensor. Now join the GPS160F cable to the remaining section of the GP310/320 cable as shown in Figure 1 below.

The connections should be made in a dry location and Digital Yacht do sell a Junction Box (JB1) that can be used to make a professional and reliable connection between the two cables.

<https://digitalyacht.co.uk/product/jb1/>

3. Wiring Diagrams

The following diagrams show how to wire the GPS160F to the most common Furuno installations. In most cases, the GPS160F will just work with no changes to the menu settings of the Furuno equipment. One exception is the GP7000 series of chart plotters, where you need to turn off the internal GPS by going to **MENU>ADVANCED>INPUT/OUTPUT** and set INTERNAL GPS to OFF.

Wiring for GP160F to replace a Furuno GP310/GP320 GPS Sensor using existing cable (MJ-A7SPF/SRMD-100)

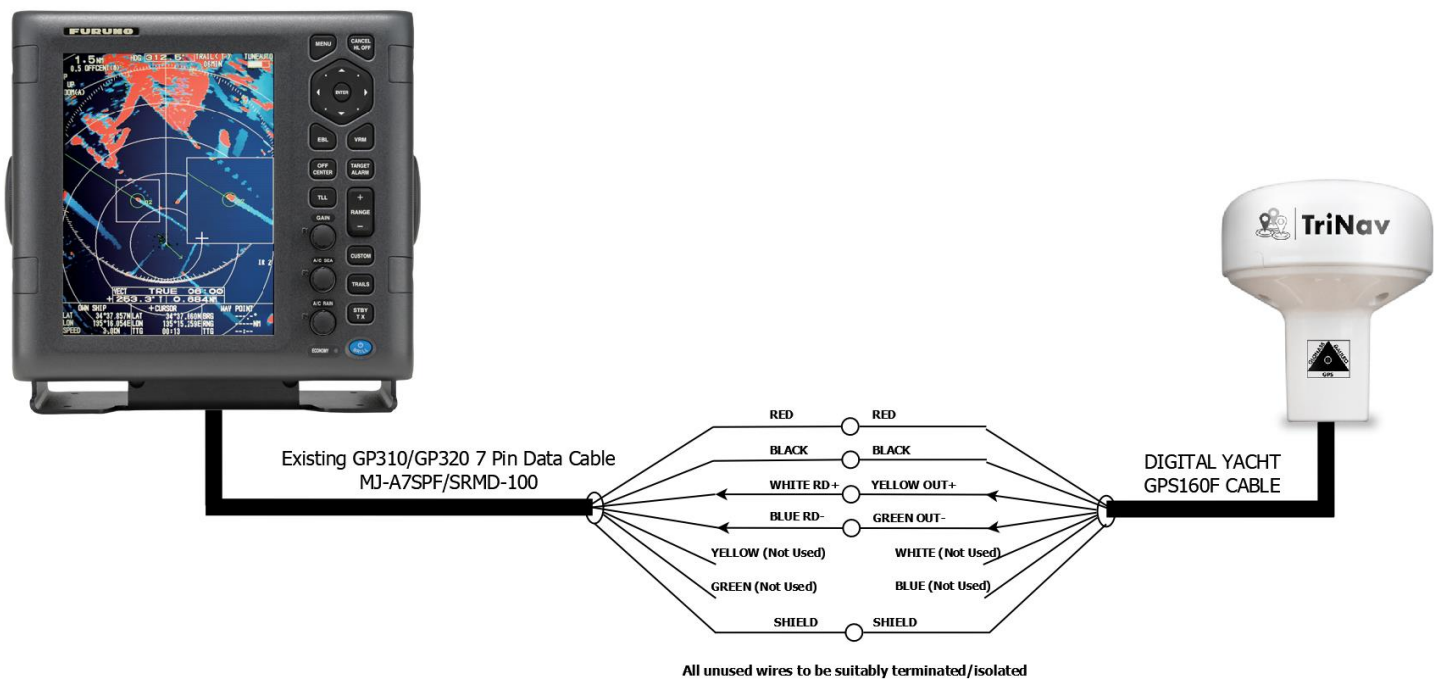

Figure 1



**Wiring for GP160F to connect to the newer 7 Pin Data Cables
(MJ-A7SPF0007-050C and MJ-A7SPF0009-020C)**

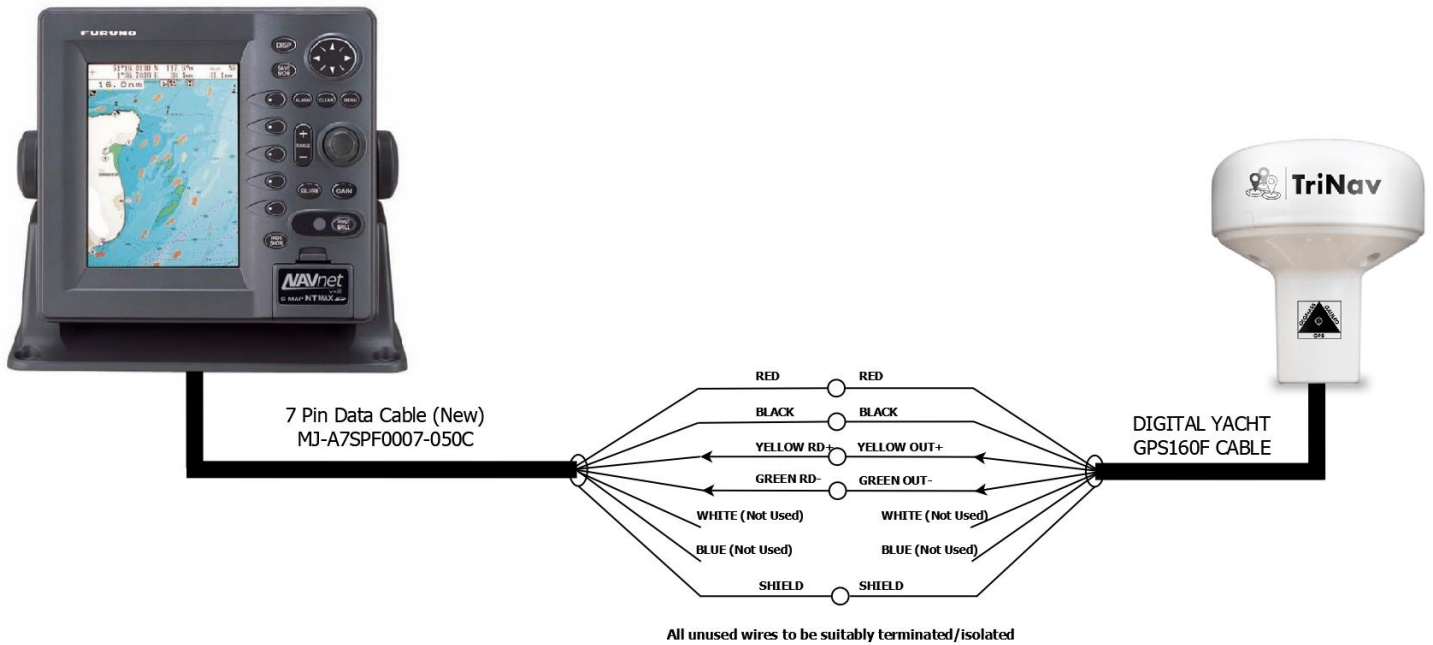

Figure 2

**Wiring for GP160F to connect to the older 7 Pin Data Cable
(MJ-A7SPF0003-050C)**

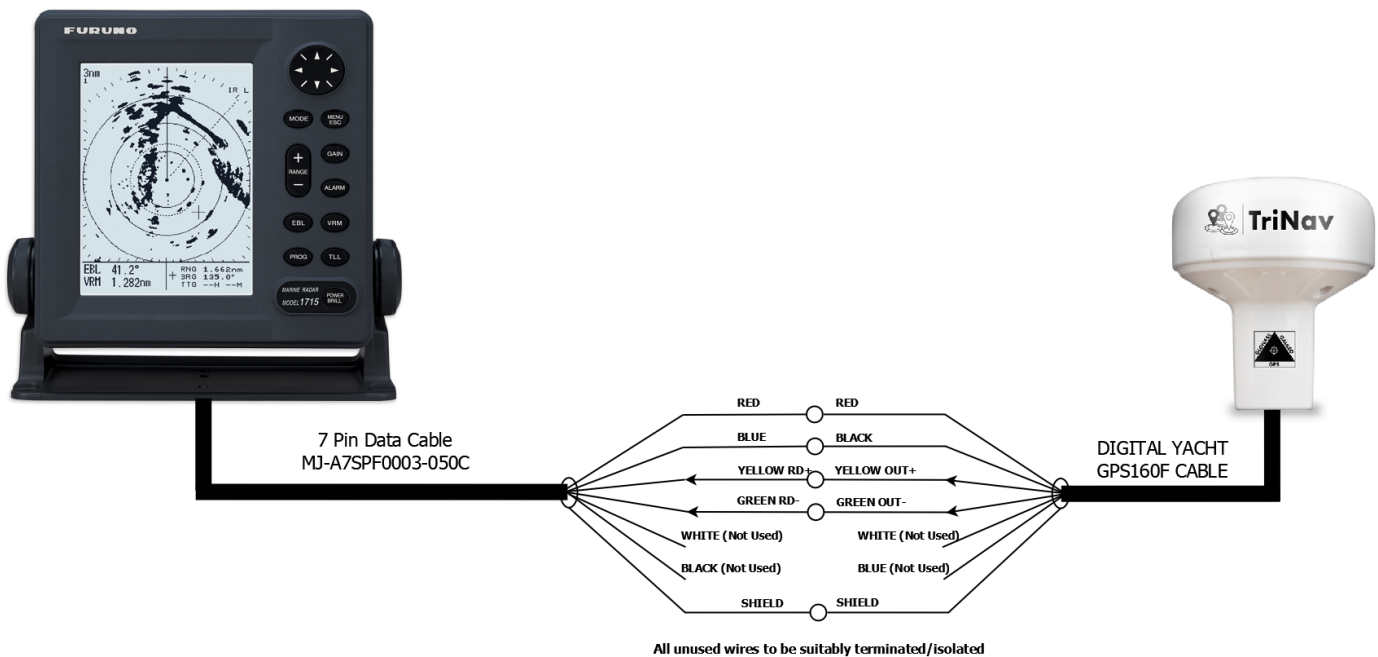

Figure 3



Wiring for GP160F to connect to the 6 Pin Data Cable (MJ-A6SPF0003-050C)

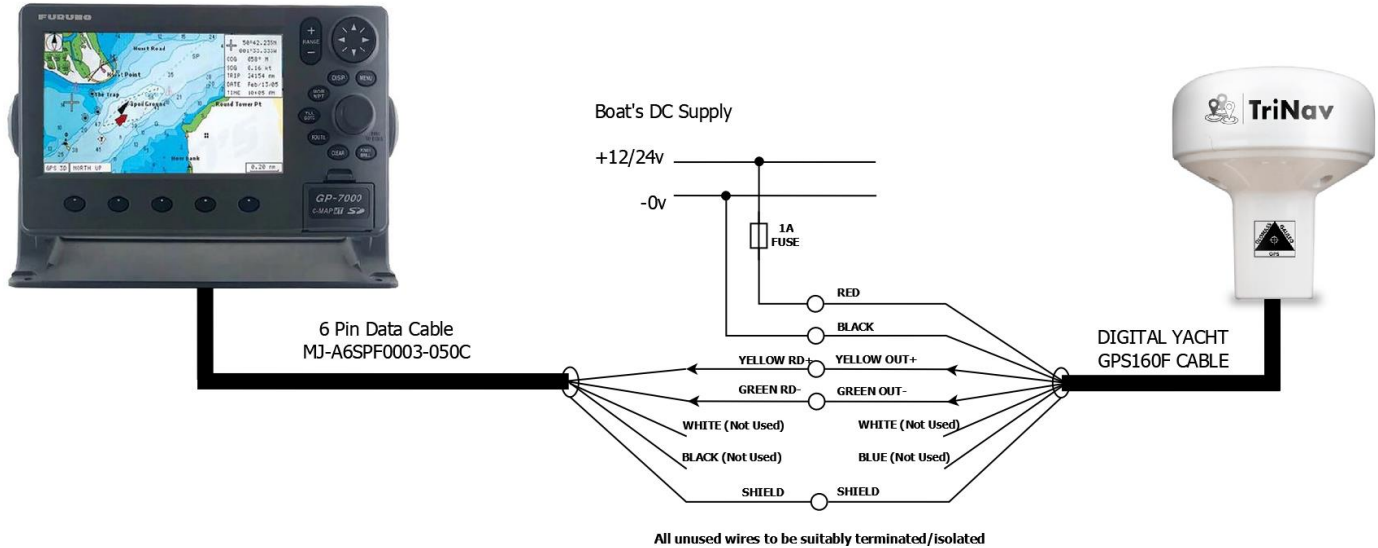

Figure 4

Wiring for GP160F to connect to the 10 Pin Data Cable (MJ-A6SPF0003-050C)

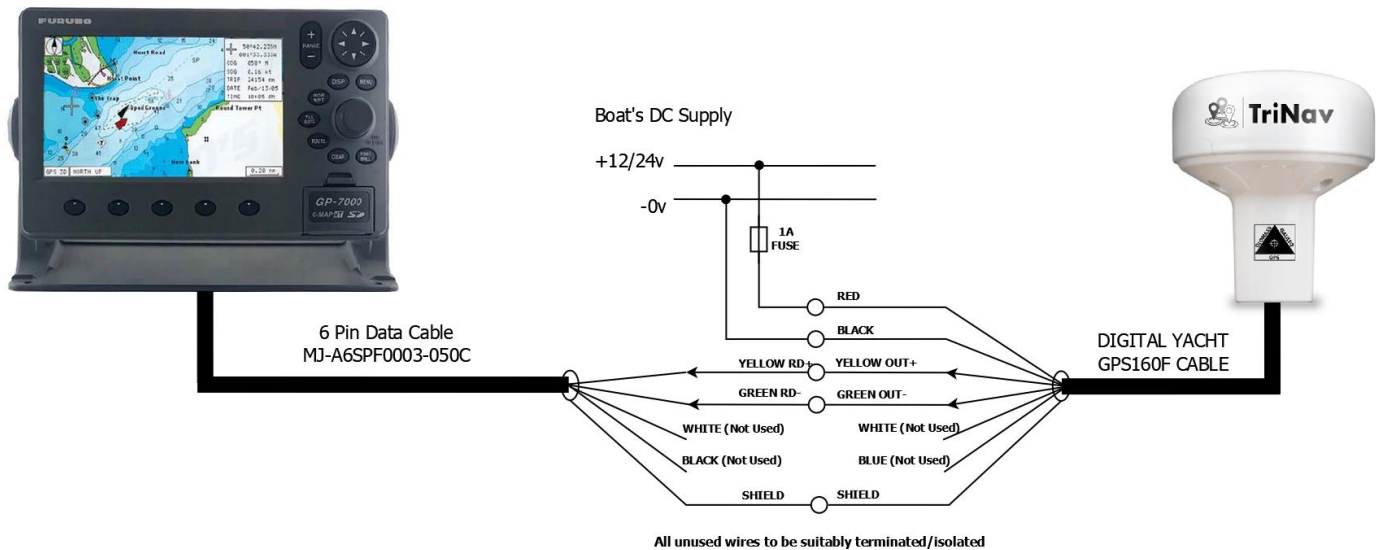

Figure 5



4. Technical Specification

Receiver	72-channel U-Blox M8 engine GPS L1C/A, SBAS L1C/A, QZSS L1C/A, QZSS L1 SAIF, GLONASS L1OF, Galileo E1B/C
Sensitivity	-165 dBm typical
Update Rate	1Hz
Accuracy Position	<1m with SBAS and 3.0-5.0m without SBAS typically (67%)
Accuracy Velocity	0.05m/sec typically (50%)
Time	± 60ns
Differential GPS	SBAS (WAAS, EGNOS, MSAS, GAGAN and QZSS)
Time to First Fix	26sec (typical)
Technology Supported	GPS, GLONASS and GALILEO
Maximum Altitude	50,000m
Maximum Velocity	500m/s
Operating Temperature	-40°C to +85°C degrees Celsius
Maximum Current	30mA (@12Volts)
Dimensions	75mm diameter, 82.5mm high (with mount), 32mm high (no mount)
Weight	300g
Protocols	NMEA-0183 Version 2.3
NMEA messages	DTM, GBS, GNS, GRS, GSA, GSV, RMC, VTG and ZDA
Power Input	VDC +9v to 34v
Cable	White 10m Shielded Cable (4.5mm OD)