

ⓘ IMPORTANT NOTES

This Manual is only applicable to HSC100 Compass Sensors manufactured after October 2025 that can be identified by new removable connector on the base of the sensor.

For earlier HSC100 compass Sensors with the M12 Gland in the base of the sensor, please refer to V1.02 of this manual.

HSC100 Compass Sensor

Installation and instruction Manual



1. Introduction

Congratulations on the purchase of your HSC100 Compass Sensor. It is recommended that your compass sensor is installed by a professional installer.

i Before operating the unit, you should also familiarise yourself again with the user manual of the equipment that you are connecting the HSC100 to. Pay particular attention to the Compass Interfacing section and any settings that need to be configured for correct operation.

2. Before you start

The HSC100 is a smart “all in one” Compass solution for small boats. Simply connect the HSC100 to a 12v or 24v DC supply and it will immediately start calculating the heading of the boat and outputting this data in NMEA 0183 format (4,800 baud). The HSC100 outputs compass data at a frequency of ten times a second, making it ideal for smooth radar overlay on chart plotters, ‘course-up’ Radar input or for driving an autopilot. It is housed in a water-resistant enclosure so it can be mounted outside in steel hulled boats.

Carefully consider how you wish to connect the HSC100 to your existing navigation system before you start installing cables. To display the Compass data, you will need:

- Suitable dedicated chart plotter or radar that can read and display Compass data via NMEA0183
- Or a suitable PC Navigation software running on a PC with Microsoft Windows XP®/Windows 2000® or Windows Vista®/Windows 7® with a free RS232 serial port or a free USB port and USB to serial port adaptor.

3. Installation

Before starting installation select a suitable location for the HSC100 Sensor. The ideal position for a fluxgate compass sensor is in the centre of the boat where pitch and roll is minimised.

The HSC100 should also be mounted as far away as possible from metal objects that are regularly moved or electrical cables/equipment.

Effects from fixed metal objects can be calibrated out, but if a metal object is placed near or moved away from the sensor after calibration, inaccuracies could occur.

The HSC100 should be fixed to a vertical bulkhead in an upright orientation using the fixing holes shown in the diagram. It does not matter which direction the HSC100 faces, as the azimuth can be set to North at any time.

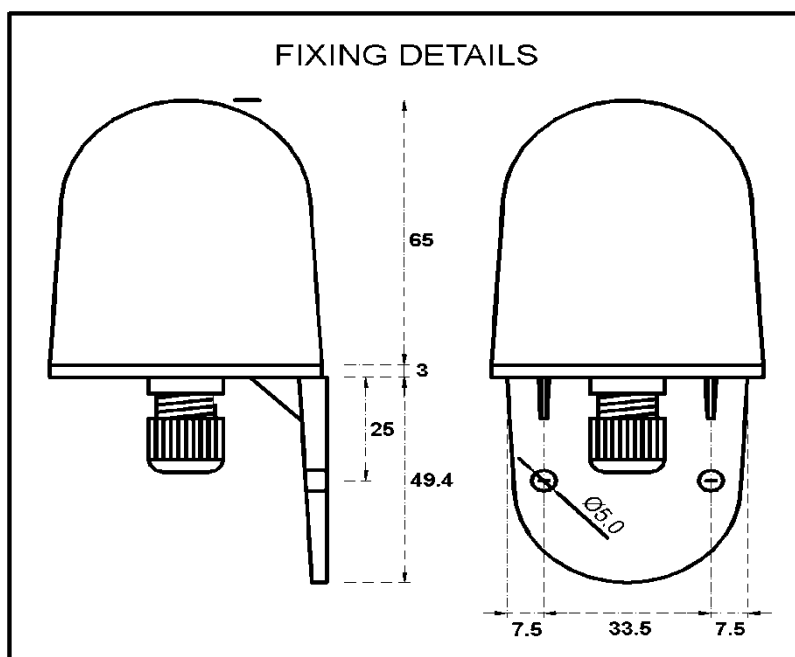



4. Electrical Connections

The HSC100 is supplied with 15m of cable, and this should be routed through the vessel to a suitable dry internal location where it can be connected to the boat's DC power system and the equipment it will be interfaced with. The cable can be shortened, lengthened or joined without problems.

The HSC100 should be connected to the boat's DC supply via a 1 Amp fuse. The unit requires 8V to 30V DC supply voltage. Typical supply current during operation is approx. 25mA. Note that the operation of the LED adds another 10mA and that during auto-calibration the consumption can be as high as 60mA.

Below are the wiring details for the HSC100 and a diagram showing the two-push button switches.

Wiring Colours;

Red	Power + (12v or 24v)
Green	NMEA IN +
Yellow	NMEA IN -
Blue	NMEA OUT +
Screen	Power - (0v)

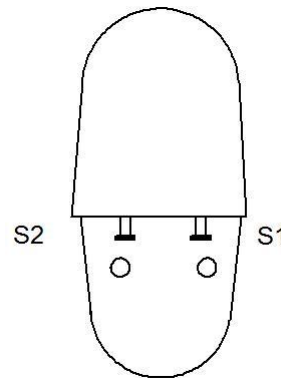

When the HSC100 is viewed from the front face, Switch 1 is on the right and Switch 2 is on the left.

- 1) Pressing Switch 1: Starts the auto-calibration process
- 2) Pressing Switch 2: Sets the current heading to Zero removing any angular offset due to mounting arrangement. The HSC100 must be mounted upright but at any azimuth. Pressing S2 sets the heading to zero and so can be done when the boat is headed North.
- 3) Pressing both Switch 1 and Switch 2 together for at least one second: Causes the autocalibration process to halt and restores the previously saved calibration values.

4.1 - HSC100 to NMEA 0183 Device Wiring Diagram

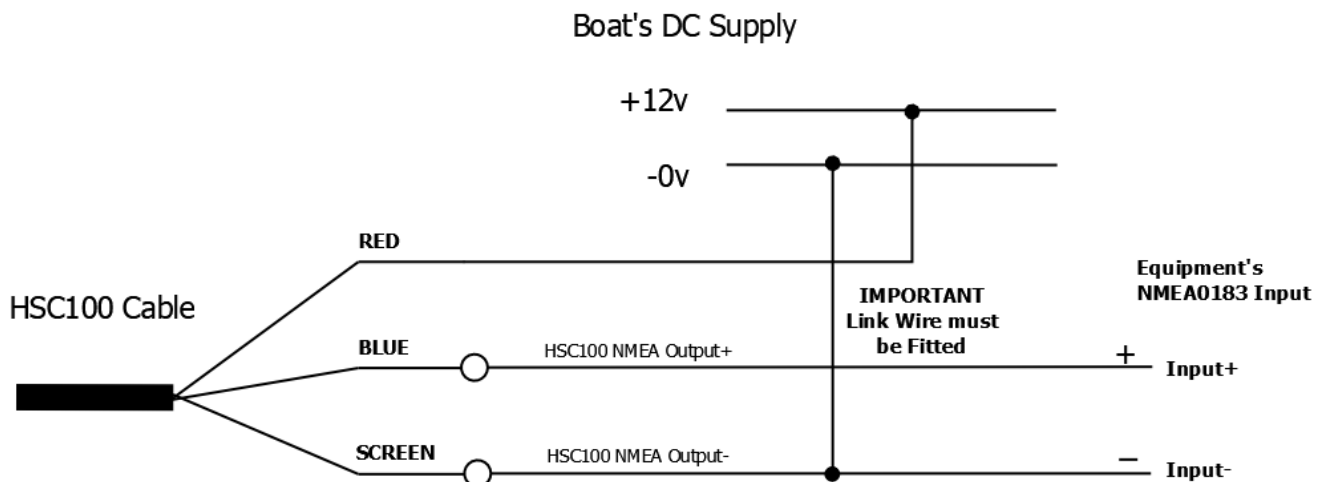



4.1 - HSC100 to USB PC Connection Wiring Diagram

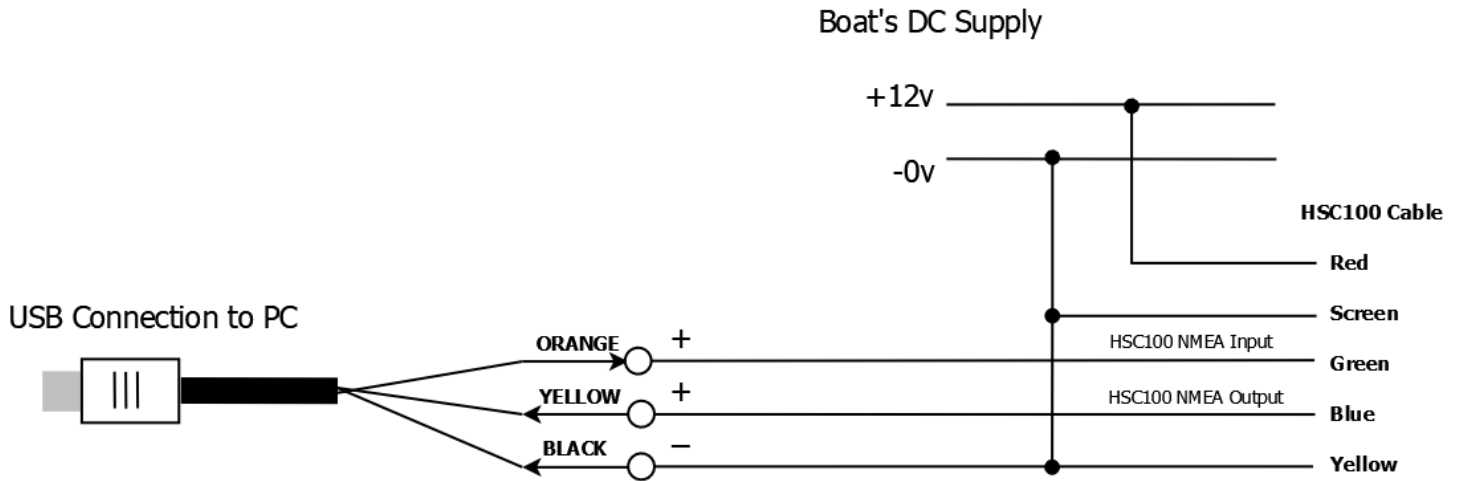

NMEA-0183 Data Output

There are two versions of the HSC100 and both output NMEA data at 4800 baud, no parity, 1 stop and start bit. The NMEA 0183 data sentences that the HSC100 outputs, will depend upon the model you have.

HSC100 - pre-configured to output **\$HCHDG,xxx.x,,,*yy**.

HSC100T - pre-configured to output **\$HEHDT,xxx.x*yy** and **\$HEROT,z.z,A*yy**

Where XXX.X = the compass heading, Z.Z = the rate of turn and YY = the NMEA checksum.

For interfacing to some systems, it is necessary to re-configure the HSC100 to output different NMEA sentences. This is possible and a Tech Note is available that explains this procedure. Please download Tech Note 00041-2012 from the Support section of our www.digitalyacht.co.uk website.



5. Calibrating the Compass

When any compass is installed the magnetic characteristics of the whole installation affect the way the Earth's field reaches the detector inside the device. Each individual installation will be different and so the HSC100 is equipped with an auto-calibration routine which corrects for these installation distortions of the magnetic field.

Calibration must always be done with the unit in its final mounted position. The essential point of the calibration is to remove the influence of nearby pieces of iron and steel –so it is essential that these remain unchanged after calibration. If any significant iron component is altered – such as the installation of new equipment or replacement of equipment such as winches or engines – then the calibration must be re-done.

Compass Calibration is best done in calm waters when no other vessels are around and with minimum wind and tide.

- 1) Steer a straight course of around 180° and when safe to do so
- 2) Start a slow turn to starboard (clockwise).
- 3) As you pass through 270° press the push button Switch 1
- 4) Continue your turn at a slow and constant speed, through a full 400°. It is important that the turn is completed at a constant rate, taking no less than 60 seconds and no more than 180 seconds.

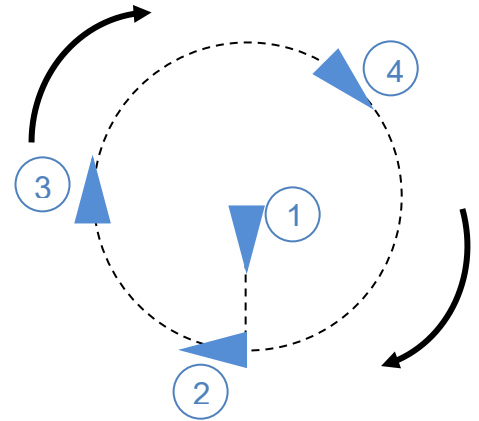

During the auto-calibration process, the Blue Status LED on the HSC100 will flash as follows;

State 1	Un-calibrated	long flash
State 2	In the process of calibration	continuous
State 3	Calibrated	short flash

If something should happen that stops you from safely completing the calibration, such as a vessel approaching or an obstruction, press and hold both push buttons together for 1 second. This will cancel the calibration and leave the unit in an un-calibrated state.

If the calibration is completed successfully, the HSC100 Status LED should change from being on continuously to short flashes.

Once calibrated, it is important to zero any alignment offset and this is done by steering the boat to North (000°) as per the conventional magnetic steering compass or the GPS course over the ground (make sure GPS is set to display magnetic headings). Once you are happy that the boat is steering a course of 000° degrees (magnetic), press push button Switch 2.

Calibration and Alignment is now complete.