

ST-NMEA (USB) CONVERTER

Installation and instruction Manual



1. Introduction

Congratulations on the purchase of your ST-NMEA (USB) Converter. This product is designed to allow SeaTalk data to be displayed on a computer and for the computer to send navigational data back on to the SeaTalk network.

Although the USB interface is simple “plug and play”, wiring the Converter to a SeaTalk network requires a level of practical ability and electrical knowledge. If you are not comfortable with electrics/electronics and making wiring connections, we recommend you have the converter installed by a professional installer/dealer.

i Before operating the unit you should also familiarise yourself again with the user manual of the SeaTalk equipment and Navigation Software that you will be using it with. Pay particular attention to the SeaTalk network wiring, the Software’s Interfacing Menu options and any other settings that need to be configured for correct operation.

2. Before you start

If you need to extend the USB cable of the ST-NMEA converter, please note that the maximum length of a standard USB cable is 5m, so avoid extending the ST-NMEA USB cable beyond this length.

To install and test the ST-NMEA (USB) converter you will need:

- Suitable tools and connectors to connect the ST-NMEA to the SeaTalk network
- M3 or M4 screws or other fixings appropriate to the mounting location
- Suitable Windows/Mac/LINUX PC with a spare USB port
- The Digital Yacht Software and Drivers CD (supplied with the ST-NMEA)
- Suitable Navigation software running on the Windows/Mac/LINUX PC that can read NMEA data

3. Installation

Before starting installation select a suitable location for the ST-NMEA. The unit is water resistant; however it should be installed below deck in a dry location. When locating the unit you should consider:

- Routing of SeaTalk and USB cables to the unit
- Provision of sufficient space around the unit for comfortable cable routing.
- Maintaining the compass safe distance of 0.5m

3.1 Connecting to SeaTalk Network

- The ST-NMEA, has a three wire SeaTalk cable with bare ended wires, providing power and data to the unit. It needs to be connected to your existing SeaTalk network but where it connects is specific to your installation.
- The SeaTalk interface was originally developed by Autohelm in the early 1990’s and was included on pretty much all Autohelm and Raymarine (and some Raytheon) products up until about 2012. This has resulted in lots of different products, interfaces, cable assemblies, etc. being out in the market, making it impossible for this manual to provide a definitive guide on connecting our ST-NMEA converter in every possible scenario.
- In any SeaTalk network there may be a variety of devices including; instruments, an autopilot, Multi-Function Display (MFD), etc. Most devices that can be fitted outside will have a proprietary SeaTalk connector of one type or another, while most autopilot course computers and below deck devices will have screw or sprung terminals, which generally are easier to connect to.
- It is recommended that you spend some time studying your SeaTalk network, to decide the best location to connect the ST-NMEA converter in to the network.



A typical large SeaTalk network diagram

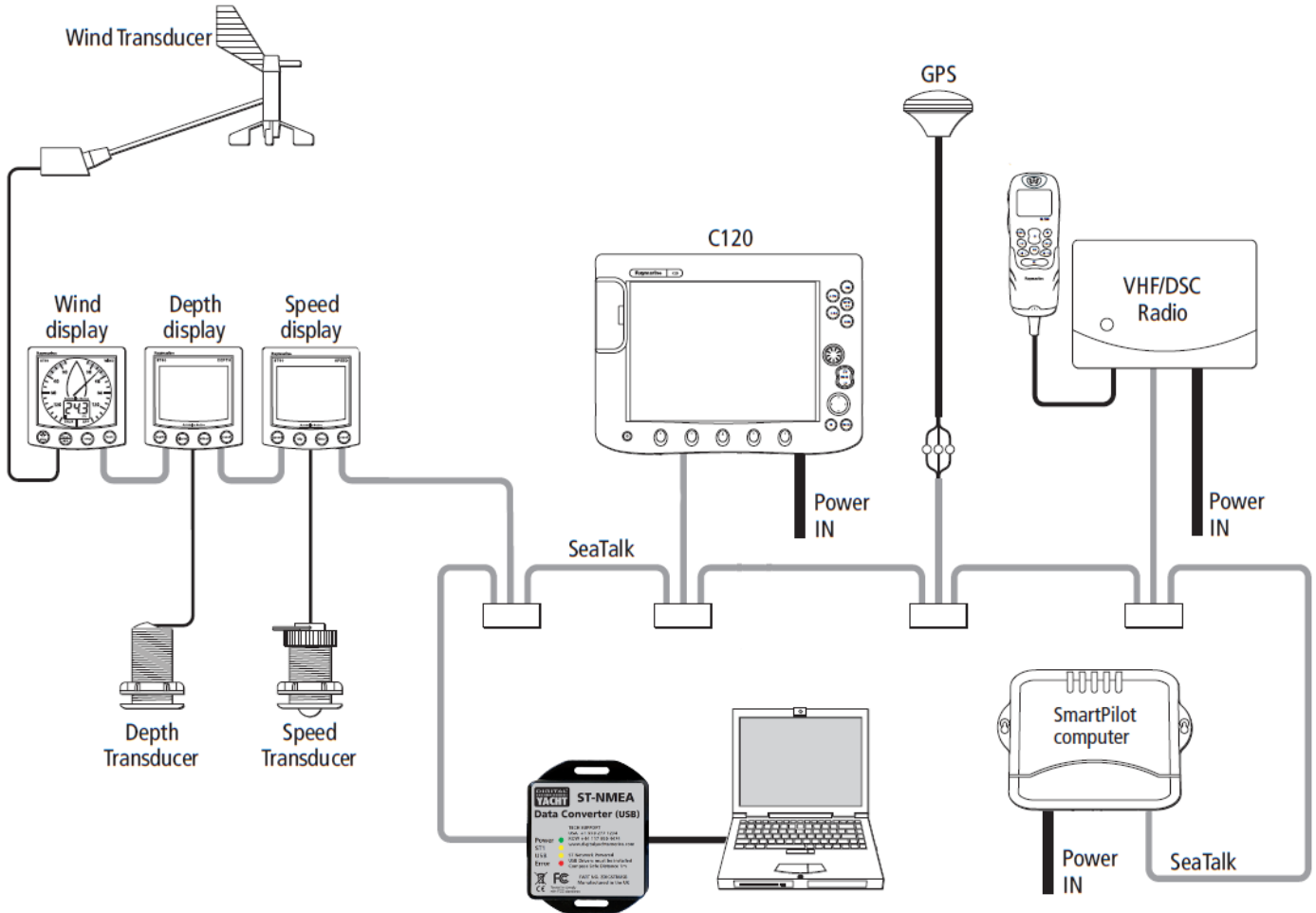

- Raymarine made a SeaTalk junction box (P/No R55006) that is a good location to connect to if you have one in your SeaTalk network...

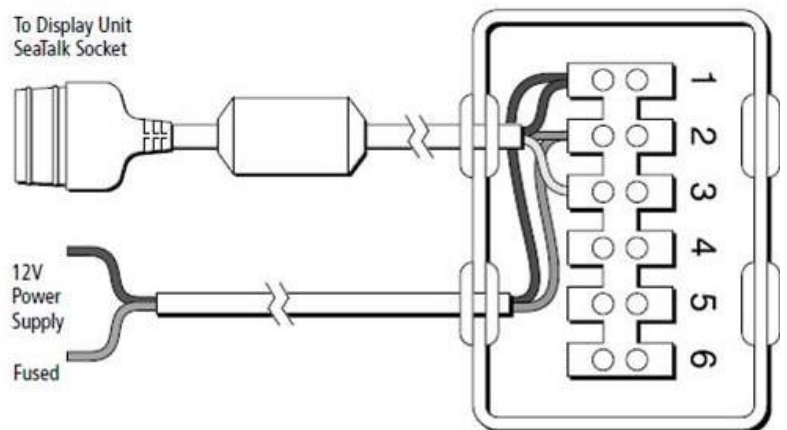



- If no obvious method of connection to the SeaTalk network exists at the location you want to mount the ST-NMEA converter, then it is possible to cut in to a SeaTalk cable and create/splice in your own connection point. **It is very important** that if you decide to do this, that you remove all 12v power from the SeaTalk network before cutting in to the SeaTalk cable.
- The three wires in a typical Raymarine/Autohelm SeaTalk network cable are;
 - RED = 12v Supply (+)
 - YELLOW = Data
 - SHIELD = 0v Supply (-)
- There are two cables on the Digital Yacht ST-NMEA ISO converter and the SeaTalk cable is the left hand, three core cable. This cable does not have a shield and the negative supply voltage wire is the Black one. After cutting in to an existing SeaTalk cable connect three wires of the ST-NMEA Converter's SeaTalk cable, so that the three RED wires are together, the three YELLOW wires are together and the Converter's BLACK wire plus the two SHIELDS are together.

3.2 Mounting

- The ST-NMEA Converter has two slotted 4mm Diameter fixing holes. Use suitable fixings (not supplied) to fix the converter to a flat surface – using the dimensions and details shown in the drawing below. Note that the unit may be installed in any orientation.

Dimension drawing

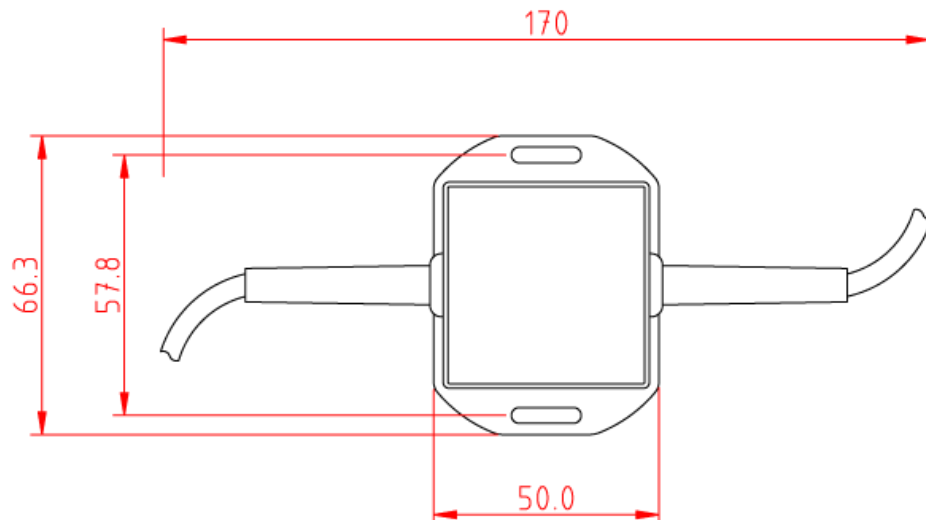

3.3 USB Connection

The ST-NMEA Converter (USB) has an integral 1m USB cable allowing it to be easily plugged in to any computer with a spare USB type A socket. Before connecting the ST-NMEA Converter to the PC, it is necessary to install the USB drivers. The exact procedure varies between the different types of Operating Systems that exist for PCs, but the following section details the procedure for the popular operating systems;

Windows XP

On the **Digital Yacht Software and Drivers CD**, there is a folder called "USB Drivers for AIS units" which contains the drivers required for the ST-NMEA Converter. Double click on the "USB Driver Setup" program and make sure that a DOS Command window opens and a series of commands are executed – normally takes 10-15secs to complete.



Once the program has finished, insert the cable of the ST-NMEA Converter in to a spare USB port and the Windows "Found New Hardware" wizard should briefly appear while the PC completes the installation.

You may need to enter the Windows Device Manager to find out what COM Port the Converter has been allocated by Windows. In the Device Manager, the ST-NMEA Converter should appear in the **Ports COM & LPT** section as a "USB Serial Port (COMx)" where x = the COM Port number allocated by Windows to the Converter. This is the COM port number that you will need to enter in your Navigation Software to tell it where to get the SeaTalk data from.

For more information on the Device Manager, visit our blog at www.digitalyacht.net and search for Device Manager. You should then be able to see an article called "Managing the Device Manager" that explains this process.

Windows Vista/7/8/10

The easiest way to install the drivers on these operating systems, is to plug the ST-NMEA Converter in to your PC when you have a good internet connection. Windows will see the new hardware and automatically search online for the latest drivers, download them and then install them. The whole process takes about 2-3 minutes and is completely automatic.

If you are on the boat and do not have an internet connection, then insert the **Digital Yacht Software and Drivers CD** in to your PC and browse to the folder called "USB Drivers for AIS units" which contains the drivers required for the ST-NMEA Converter. Right click on the "USB Driver Setup" program and select the option "Run as administrator". The program should now open a DOS Command type window and execute a series of commands – normally takes 10-15secs to complete.

Once the program has finished, insert the cable of the ST-NMEA Converter in to a spare USB port on the PC and the Windows "Found New Hardware" wizard should briefly appear while the PC completes the installation.

You may need to enter the Windows Device Manager to find out what COM Port the Converter has been allocated by Windows. In the Device Manager, the ST-NMEA Converter should appear in the **Ports COM & LPT** section as a "USB Serial Port (COMx)" where x = the COM Port number allocated by Windows to the ST-NMEA Converter. This is the COM port number that you will need to enter in your Navigation Software to tell it where to get the SeaTalk data from.

For more information on the Device Manager, visit our blog at www.digitalyacht.net and search for "Device Manager". You should then be able to see an article called "Managing the Device Manager" that explains this process.

Mac Os X

If you are using the ST-NMEA Converter with a Mac, you will need to install the drivers before connecting the Converter to a spare USB port on the Mac.

On the **Digital Yacht Software and Drivers CD**, there is a folder called "USB Drivers for AIS units" which contains a sub-folder called "Mac OSX" in here is one DMG file that you need to double click on to run. Follow the instructions that are displayed and at the end of the installation the USB drivers for the Converter should be installed.

For more information on installing the USB drivers on a Mac please download our [Tech Note 00013-2010](#) which explains the whole procedure in more details.

LINUX

The good news for LINUX users is that the USB drivers for the ST-NMEA Converter are already included in the Kernel and it is simply a case of plugging the Converter in to a spare USB port on the PC.

However, recently we have received reports of changes to the way Ubuntu handles COM ports which has caused some problems for our customers. Please visit our blog at www.digitalyacht.net and search for "Ubuntu". You should see an article that explains this issue and how to fix it.



4. Operation

4.1 Power Up

The ST-NMEA Converter is designed to start converting data as soon as it powers up and no setup or configuration is required.

As it powers up all four of the LEDs will flash once and then either the Yellow “ST” or “NMEA” LED will come illuminate or flash to indicate what mode and baud rate the ST-NMEA Converter is set to (see section 4.x).

After about 1 second, the Yellow LEDs will go off and the Green “Power” LED should turn ON to indicate that the unit has powered up correctly.

As data starts to be received from the SeaTalk network or on the USB interface (from the computer) the Yellow “ST1” and “NMEA” LEDs will flash. If they are not flashing, then no data is being received on that interface.

The Red “Error” LED indicates a data transmission issue and if it should illuminate or flash please contact Digital Yacht.

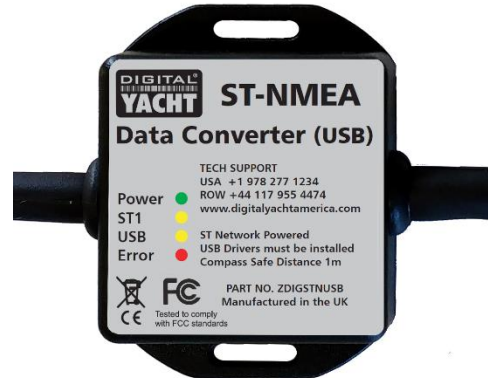

4.2 Data Conversions

All supported NMEA Sentences received will be converted into SeaTalk data, as long as that type of data is not already on the SeaTalk network i.e. if an NMEA depth sentence is received, but there is already a SeaTalk Depth Instrument putting depth data on to the SeaTalk network, then the NMEA depth sentence would not be converted.

If you are using the ST-NMEA Converter to send data from a PC to the SeaTalk network, then it is important that the same data is not already on the SeaTalk network otherwise the ST-NMEA Converter will not do the conversion. If for instance you are sending Nav Data from a chart plotting program to drive a SeaTalk Autopilot, ensure no other SeaTalk devices are also outputting that same type of data

Here is a list of the current NMEA0183 Sentence Conversions that the ST-NMEA Converter Supports and update rates:

OUTPUT (Convert from SeaTalk to USB)

INPUT (Convert from USB to SeaTalk)

APB	1 sec
DPT	1 sec
HDG	1 sec
MTW	4 sec
MWV	1 sec
RMB	1 sec
RMC*	1 sec
RSA	1 sec
VHW	1 sec
VLW	4 sec

DPT
HDG
MTW
MWV
RMC
VHW

* NOTE – Time UTC from GPS is only updated every 10 secs on the SeaTalk network

If the ST-NMEA receives more NMEA Sentences than the SeaTalk Network can handle it will automatically filter/discard excessive sentences, so you can connect a 10Hz GPS or Compass sensor without flooding the SeaTalk network.



4.3 \$STALK Mode and 38400 Baud Rate

Some software systems can read/write the raw SeaTalk data using a special \$STALK sentence. By default our ST-NMEA Converter powers up in what we call "Normal" mode where it converts SeaTalk to/from standard NMEA0183 Sentences at 4800 baud. However, by sending it the following proprietary commands, it can be put in to \$STALK mode and also work at the higher NMEA0183 baud rate of 38400.

To turn ON/OFF the special \$STALK mode use these commands;

```
$PDGY,STalk,On  
$PDGY,STalk,Off
```

To change the baud rate use these commands;

```
$PDGY,Baud,38400  
$PDGY,Baud,4800
```

If you intend to use the \$STALK mode, we do recommend selecting the 38400 baud rate.

Note that the above commands do not need a checksum, but your terminal program will need to transmit the command with <CR><LF> characters at the end. You will receive an acknowledgement from the ST-NMEA Converter.

The Mode and Baud Rate settings are saved in Non-Volatile memory and so the ST-NMEA converter will always power up in the selected Mode and Baud rate. During Power Up, the two Yellow LEDs; "ST" and "NMEA" will illuminate to show what mode and baud rate are set...

<u>LED Status</u>	<u>Mode/Baud Rate</u>
"NMEA" On for 1 sec	"Normal" Mode 4800 baud
"NMEA" Flash for 1 sec	"Normal" Mode 38400 baud
"ST" On for 1 sec	"\$STALK" Mode 4800 baud
"ST" Flash for 1 sec	"\$STALK" Mode 38400 baud

IMPORTANT NOTES

1. SeaTalk™ is a registered trademark of Raymarine UK Limited.
2. Digital Yacht is not in anyway connected or associated with Raymarine UK Limited or its associated companies.
3. No liability can be accepted for any injuries, damage or loss caused by using this ST-NMEA Converter.