



Article Number - 00016-2011

Date - 18<sup>nd</sup> Jan 2012

Article applies to - **All Digital Yacht AIS products with NMEA Input (Multiplexer)**

### **ISSUE: Connecting a Digital Yacht AIS to a Raymarine Classic C Series**

The original Raymarine C Series multi-function display (MFD), now referred to as the “Classic” C Series, is a very popular chart plotter that supports connection to an AIS unit via NMEA 0183. The “Classic” C Series only has one NMEA 0183 port and this is often connected to other devices, which can cause complications when a customer wishes to add AIS to the system.

Digital Yacht have designed and tested a number of solutions to this problem and this technical article details how to connect a Digital Yacht AIS to this popular multi-function display. Only Digital Yacht products that have an NMEA 0183 input (multiplexer) can be used in some of the solutions we outline in this document so please check that your Digital Yacht AIS has this feature before purchasing.

### **SOLUTIONS:**

On the rear of the C Series are six connections. The five pin NMEA In/Out cable is the one that we need to connect the AIS to. The diagram below shows the wire colours and connections.

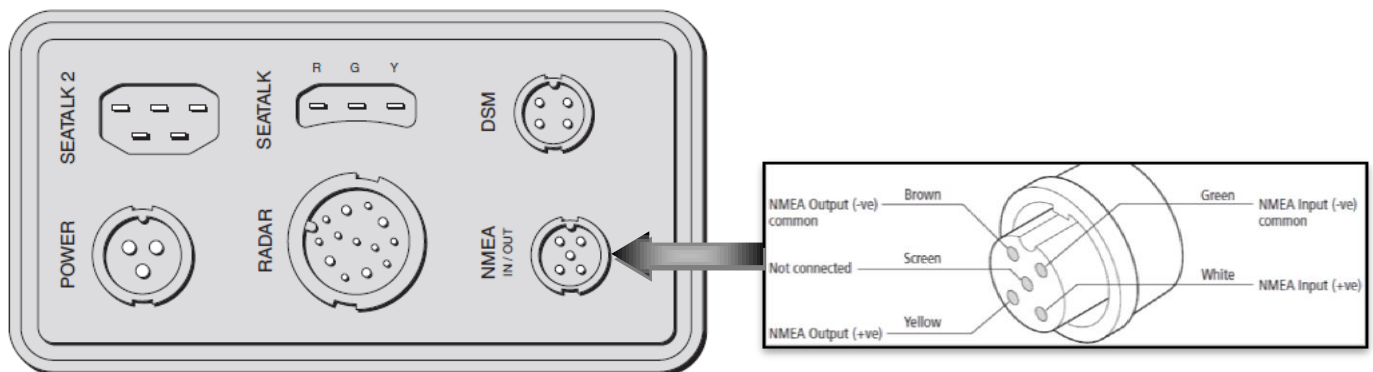

Check this cable to see if any other equipment is already connected to it. The two most common NMEA connections to the C Series are;

- 1) The C Series Output (GPS position) is connected to a DSC VHF
- 2) The C Series Input is connected to the High Speed Heading output from a Raymarine Autopilot Course Computer or other compass sensor.

If your installation is configured in either of these two ways, jump to the relevant solution on the following pages.

**\*\*\* We strongly recommend that all C Series Classic units are updated to the latest V5.04 software (Oct 2010) as this fixes a number of important AIS related bugs. \*\*\***

### Solution 1 – No existing connections to the NMEA In/Out

If you check the C Series NMEA cable and find no other NMEA connections are currently made, then you can simply connect the Digital Yacht AIS NMEA 0183 Output to the C Series NMEA Input as shown below;

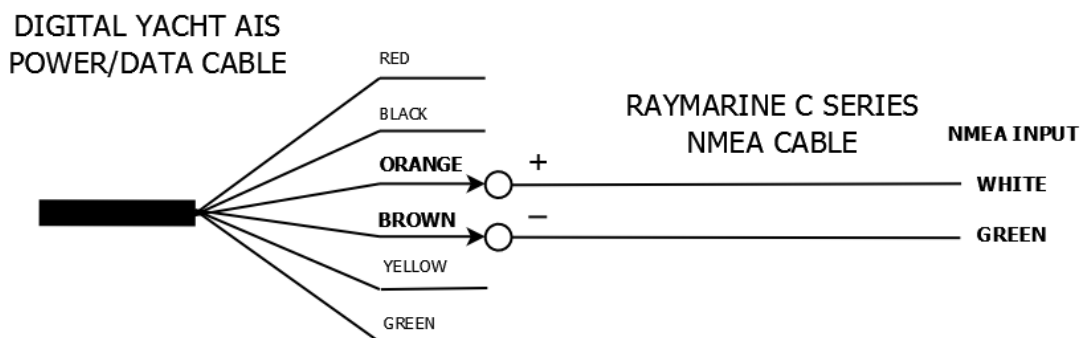

### Solution 2 – The C Series NMEA Out is connected to a DSC VHF

If you check the C Series NMEA cable and find that it is connected to a DSC VHF, then you will need to configure the Raystar 125 GPS to work on NMEA 0183 rather than SeaTalk. The diagram below shows how the system is currently connected (left) and how the system needs to be reconnected (right).

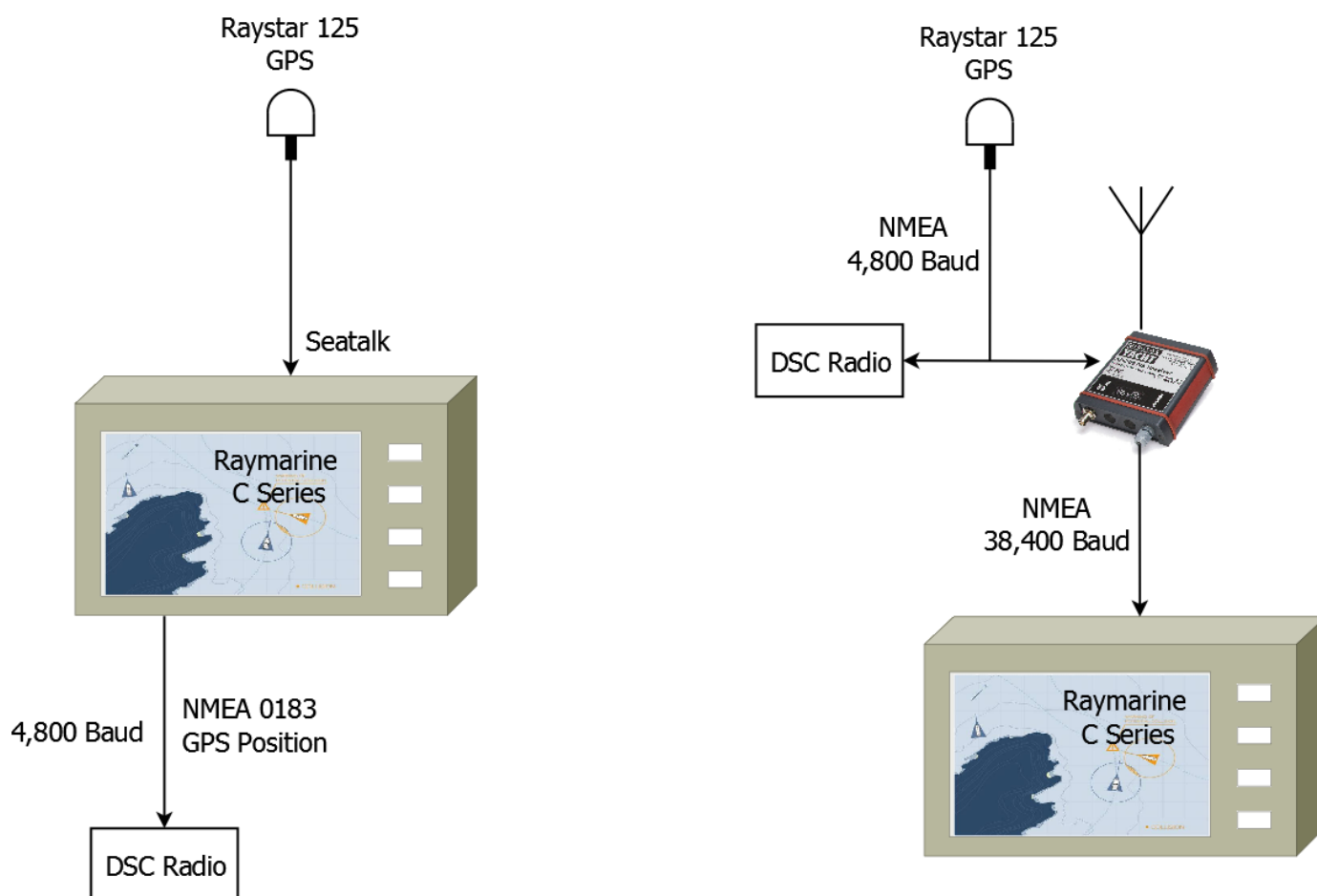

Consult the Raymarine manual for the Raystar 125 on how to configure it to work on NMEA0183 rather than SeaTalk, but the connections you will need to make are shown below. The Raystar 125 GPS data will now be multiplexed with the AIS data and output to the C Series at the NMEA (HS) 38,400 baud rate.

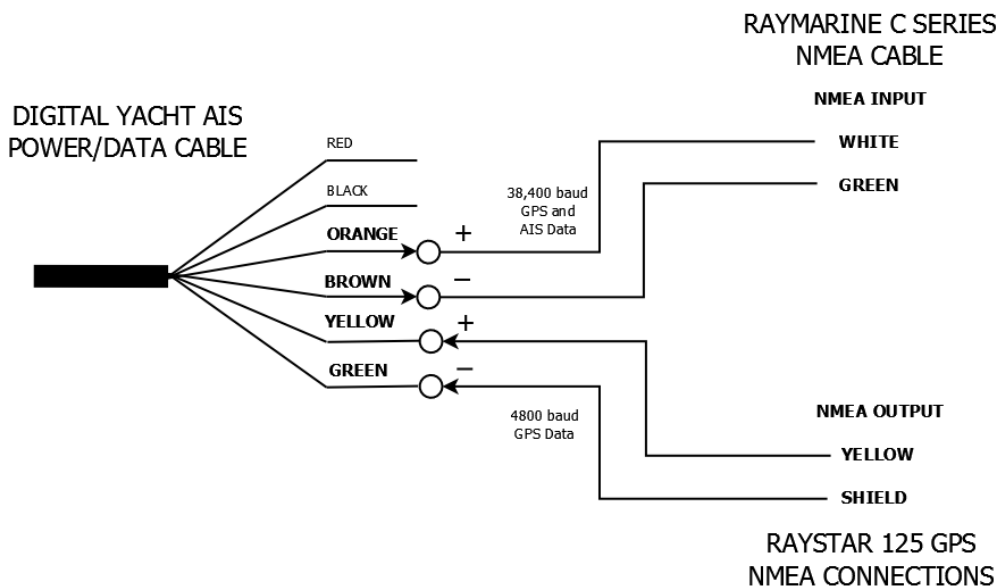

### Solution 3 – The C Series NMEA Input is connected to a High Speed Compass

If you check the C Series NMEA cable and find it is connected to the NMEA High Speed Compass output of a Raymarine autopilot course computer or other heading sensor, then you will need to disconnect this NMEA High Speed Compass output from the C Series input and connect it to input of the Digital Yacht AIS unit. This compass data will then be multiplexed with the AIS data and output to the C Series at the NMEA (HS) 38,400 baud rate.

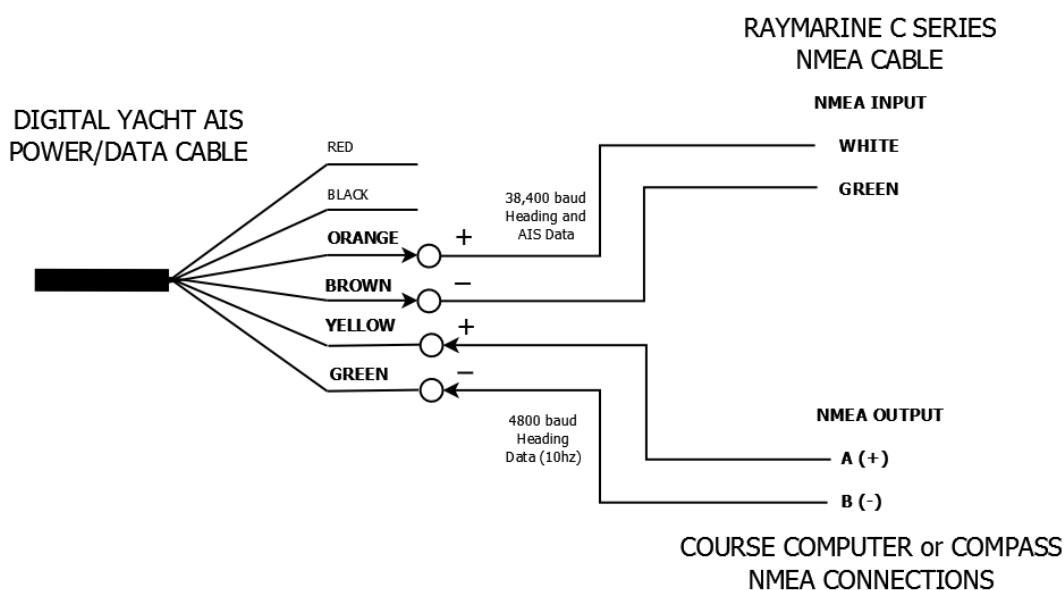

**IMPORTANT NOTE:-** The above diagrams are applicable to all Digital Yacht AIS units except the ANT200. For the ANT200 the NMEA output wire is Grey (not Orange).